



US009539480B1

(12) **United States Patent**
Boswell

(10) **Patent No.:** **US 9,539,480 B1**
(45) **Date of Patent:** **Jan. 10, 2017**

- (54) **GOLF TEE MEASURING APPARATUS AND DIVOT REPAIR TOOL**
- (71) Applicant: **Thomas K. Boswell**, Elk Ridge, UT (US)
- (72) Inventor: **Thomas K. Boswell**, Elk Ridge, UT (US)
- (*) Notice: Subject to any disclaimer, the term of this patent is extended or adjusted under 35 U.S.C. 154(b) by 0 days.
- (21) Appl. No.: **14/804,173**
- (22) Filed: **Jul. 20, 2015**
- (51) **Int. Cl.**
A63B 57/50 (2015.01)
A63B 57/00 (2015.01)
- (52) **U.S. Cl.**
CPC *A63B 57/0037* (2013.01); *A63B 57/0032* (2015.10); *A63B 57/0068* (2013.01); *A63B 57/50* (2015.10)
- (58) **Field of Classification Search**
CPC *A63B 57/50*; *A63B 57/0032*; *A63B 57/10*; *A63B 57/0037*
See application file for complete search history.

5,388,824 A *	2/1995	Reimers	A63B 57/00	473/406
5,645,500 A *	7/1997	Borden	A63B 57/00	473/286
6,413,173 B1 *	7/2002	Muller	A63B 57/50	473/408
6,413,174 B1 *	7/2002	Roberts	A63B 57/50	473/408
D468,385 S *	1/2003	Fleischmann	D21/793	
D473,279 S *	4/2003	Fleischmann	D21/789	
7,044,866 B1 *	5/2006	Blauvelt	A63B 57/10	224/918
7,841,096 B1 *	11/2010	Jenkins	A63B 57/0037	33/485
7,850,550 B2 *	12/2010	Nania	A63B 57/0037	473/386
D676,918 S *	2/2013	Jenkins	D21/789	
2008/0188328 A1 *	8/2008	Joffe	A63B 57/10	473/386
2009/0098952 A1 *	4/2009	Leiber	A63B 57/50	473/408
2011/0081994 A1 *	4/2011	Rourke	A63B 57/50	473/408

* cited by examiner

Primary Examiner — Steven Wong
(74) Attorney, Agent, or Firm — Steven Rinehart

(57) **ABSTRACT**

A golf tee measuring device and divot repair tool is provided for measuring the length of a golf tee, repairing divots, and housing a marker, the device comprising a housing defining an open aperture, a positioning slot within which a button travels, and an interior recess. The device further comprises a lower component having two extrudable prongs for repairing divots, the lower component defining a guide track recessed into an interior surface.

11 Claims, 10 Drawing Sheets

- (56) **References Cited**
U.S. PATENT DOCUMENTS
- 4,151,937 A * 5/1979 Jarosh A45C 11/00 206/315.1
- 4,535,987 A * 8/1985 Dikoff A63B 57/00 116/225

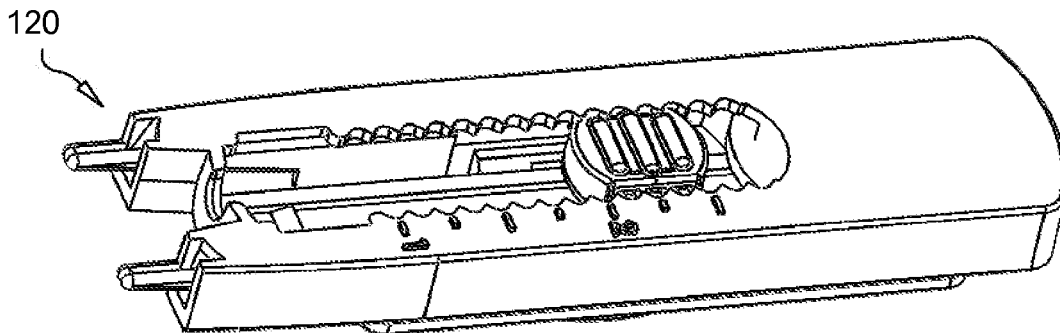

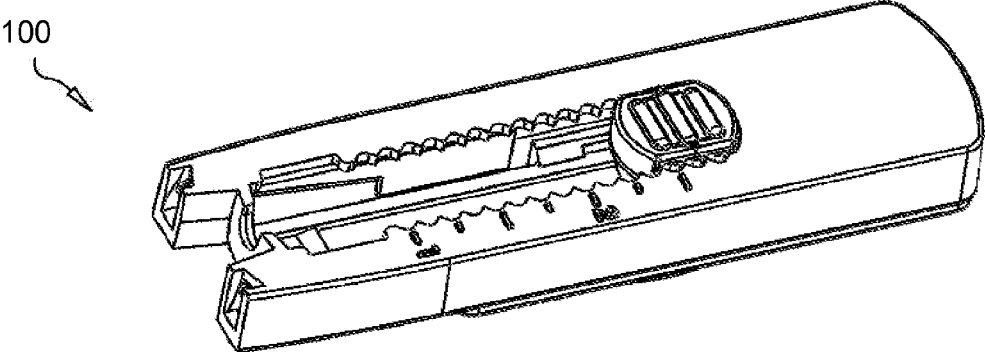

FIG. 1A

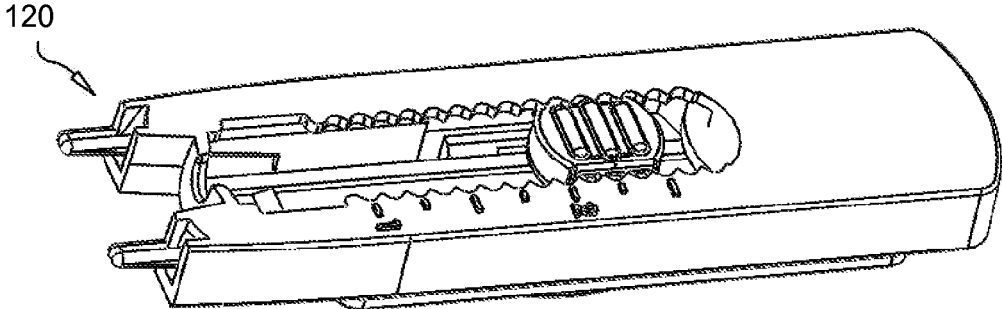

FIG. 1B

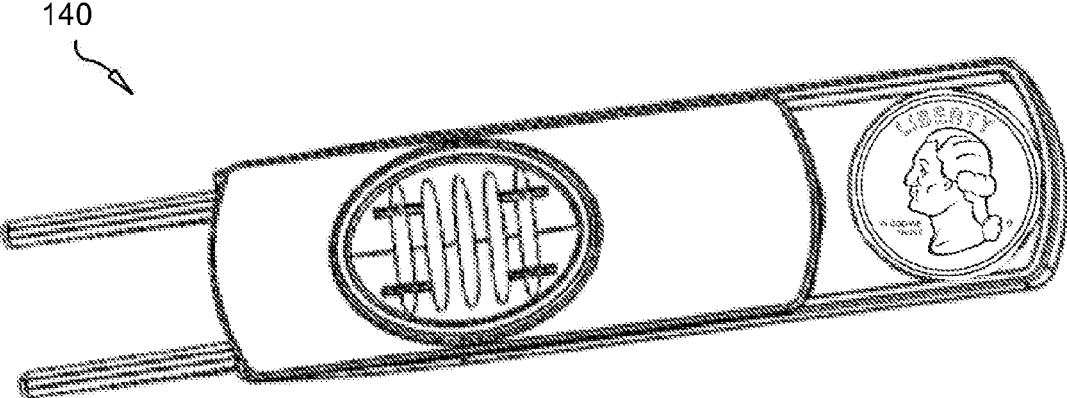

FIG. 1C

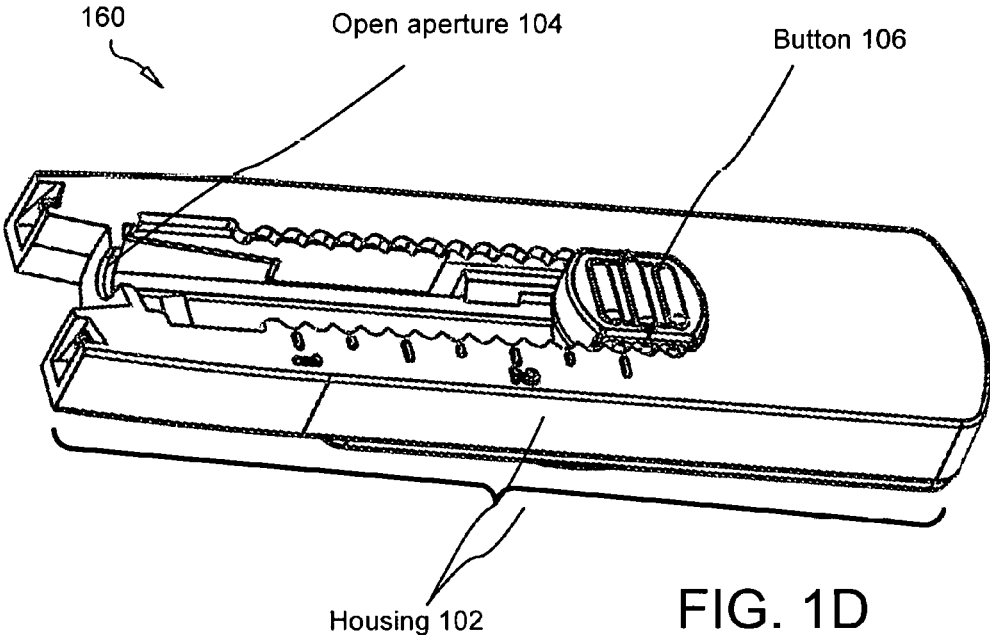

FIG. 1D

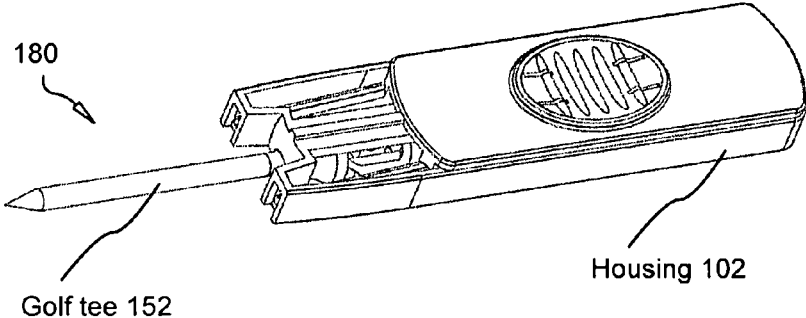

FIG. 1E

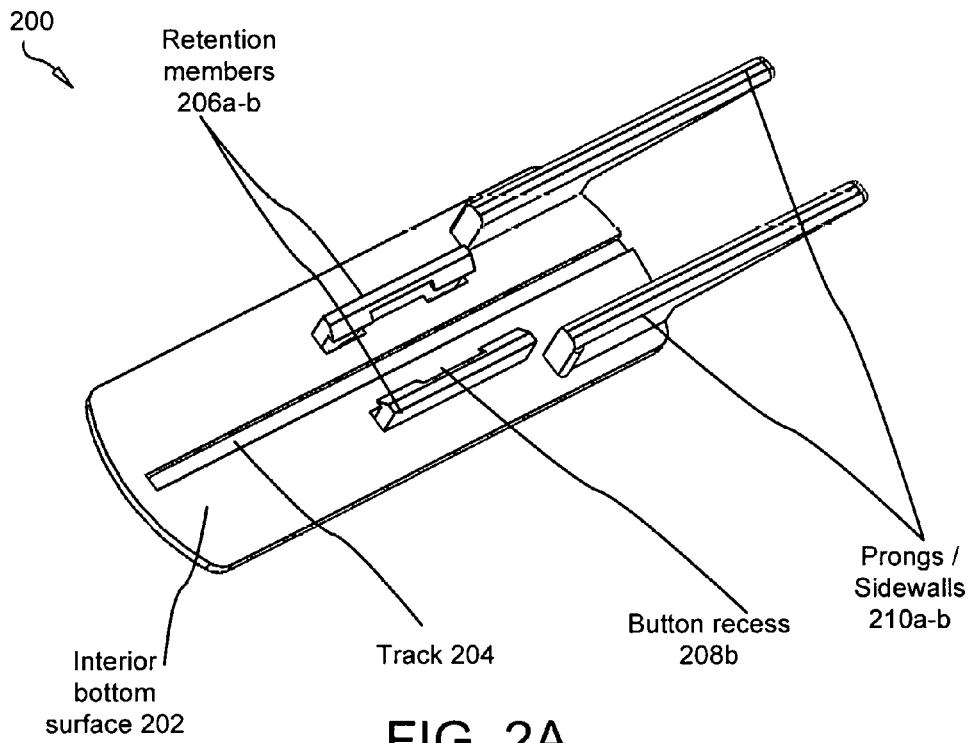

FIG. 2A

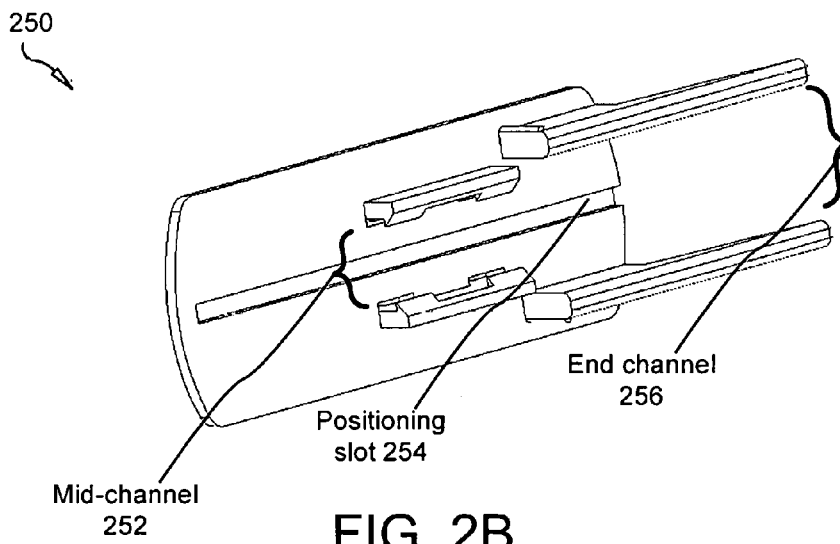

FIG. 2B

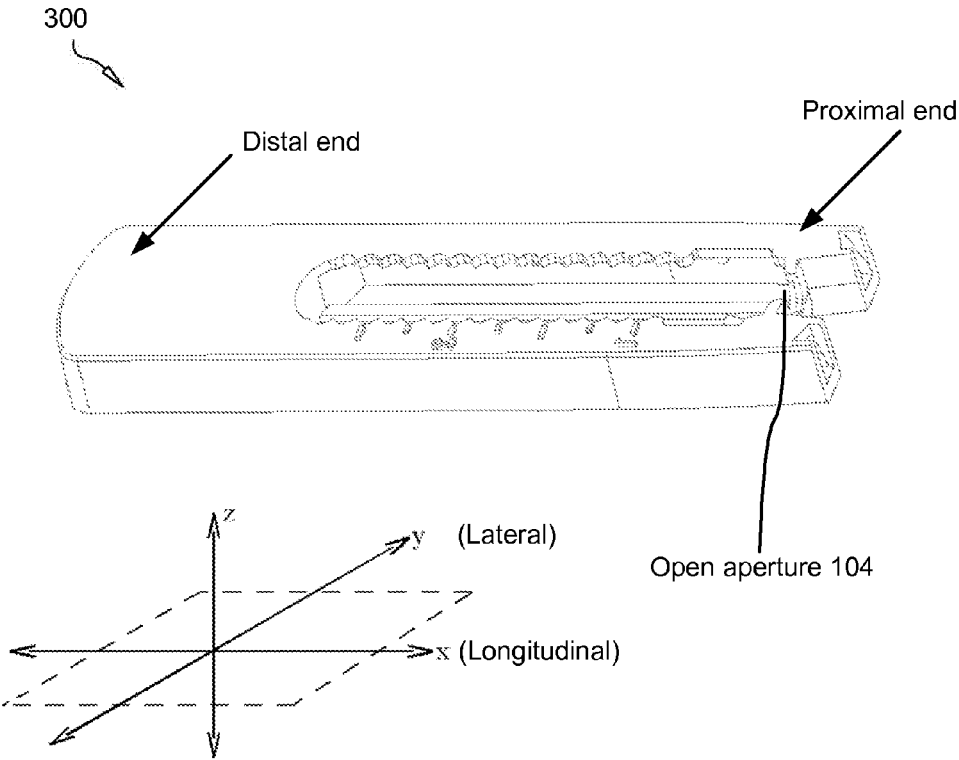

FIG. 3

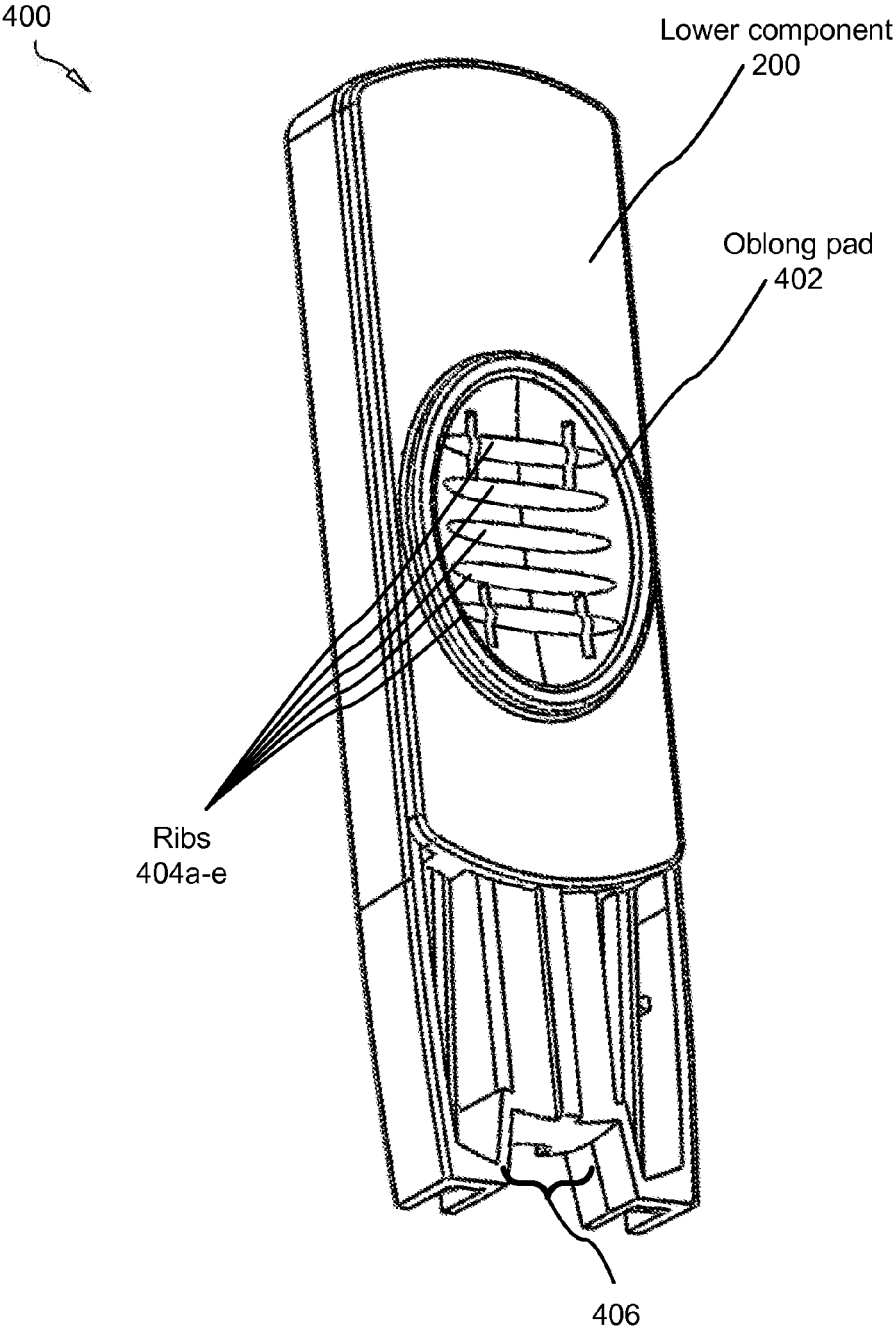

FIG. 4

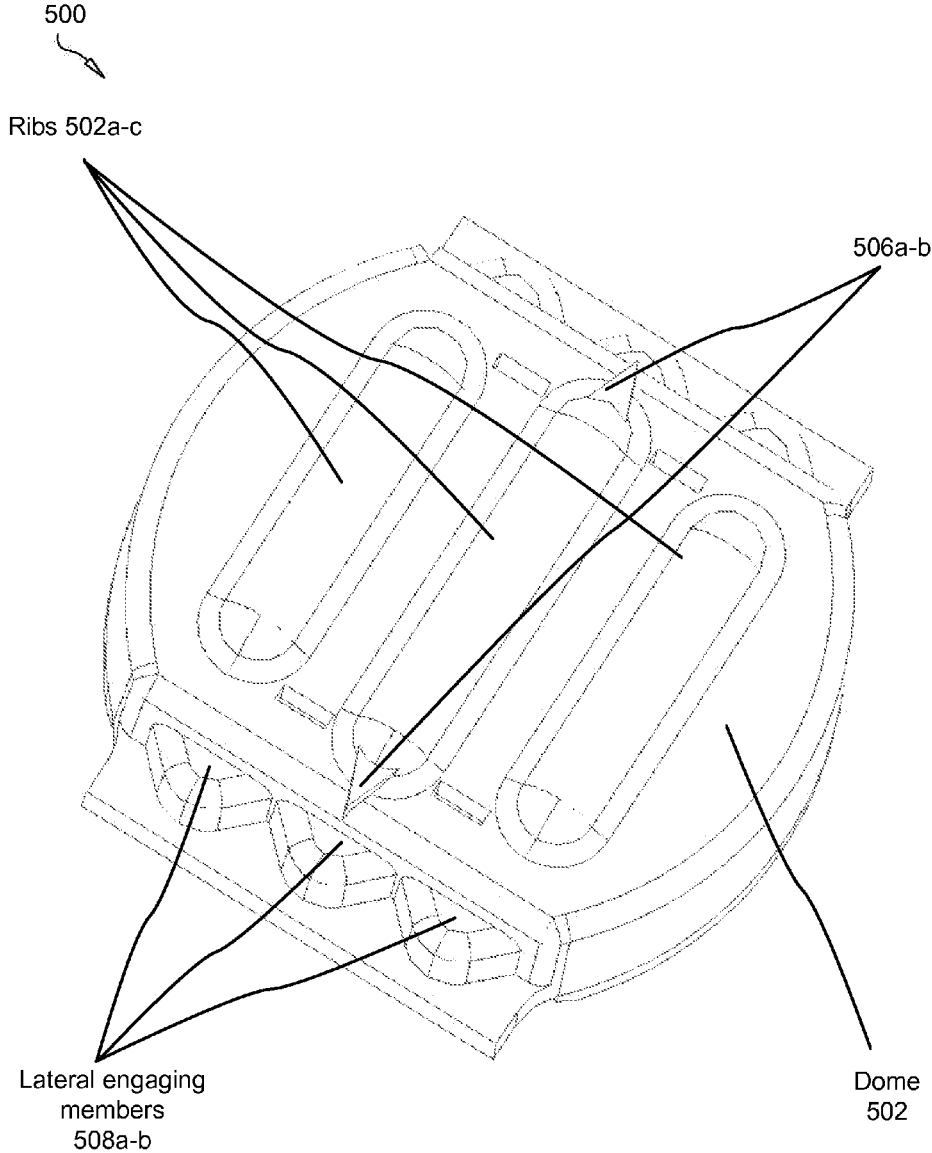

FIG. 5A

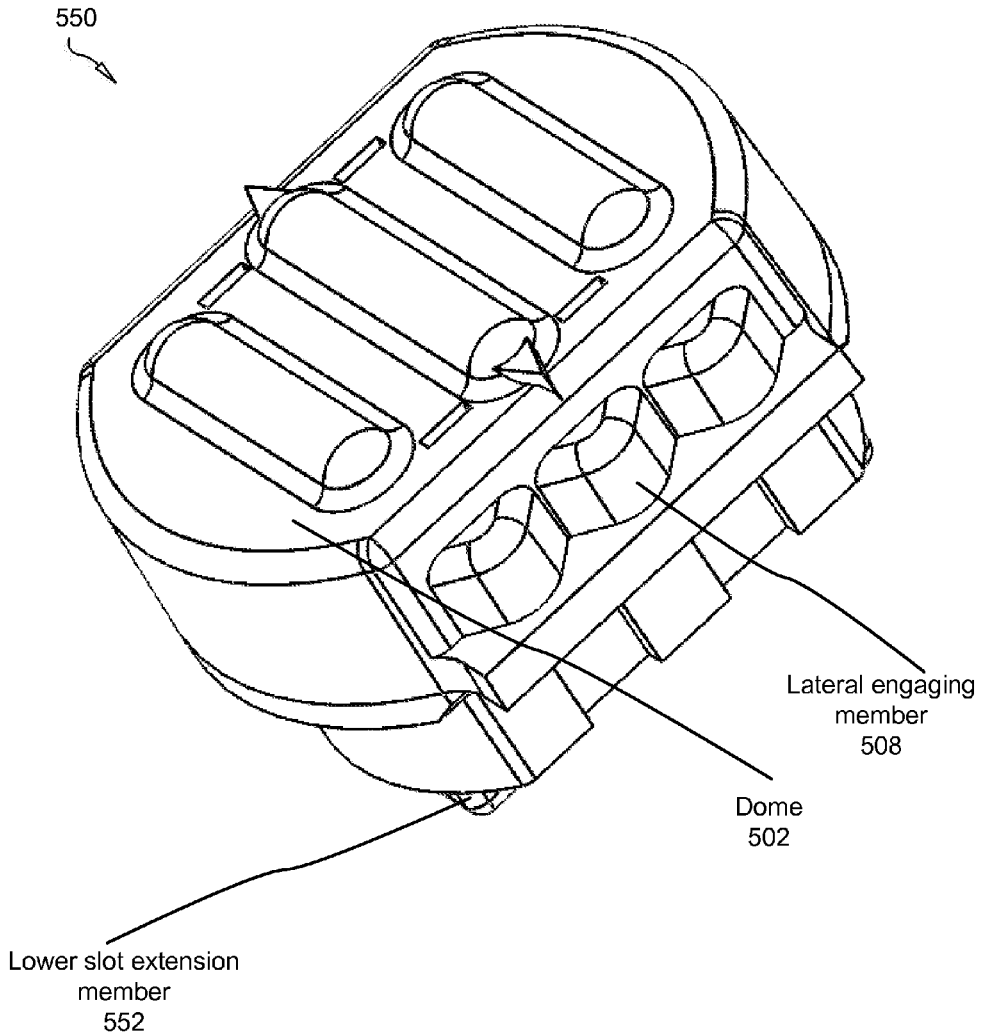

FIG. 5B

600
↙

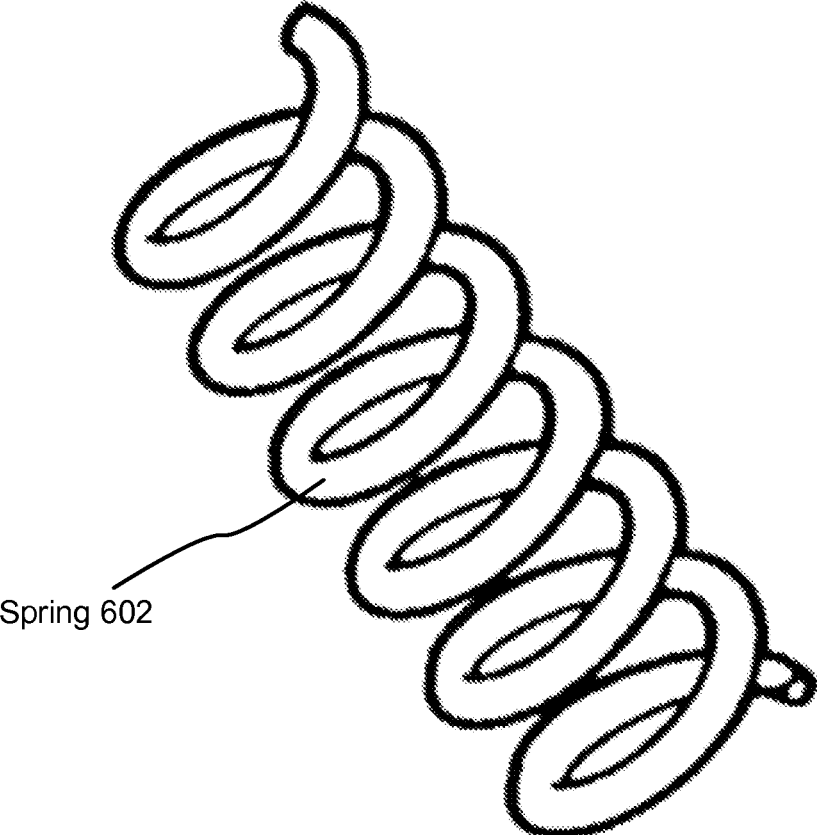
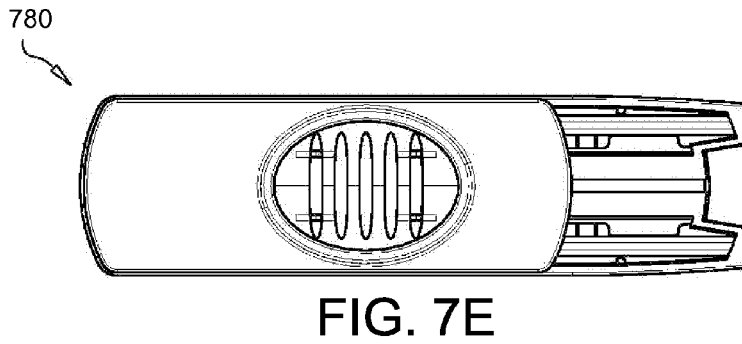
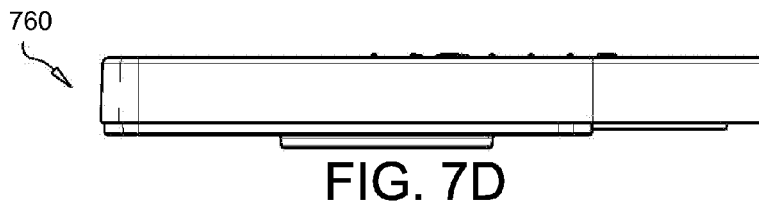
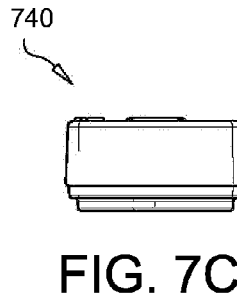
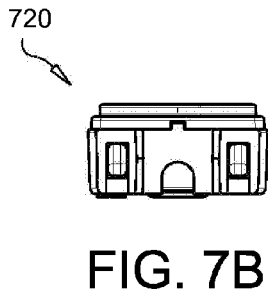
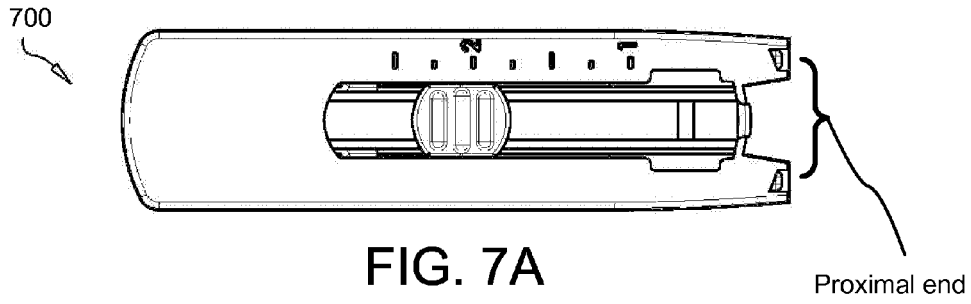

FIG. 6



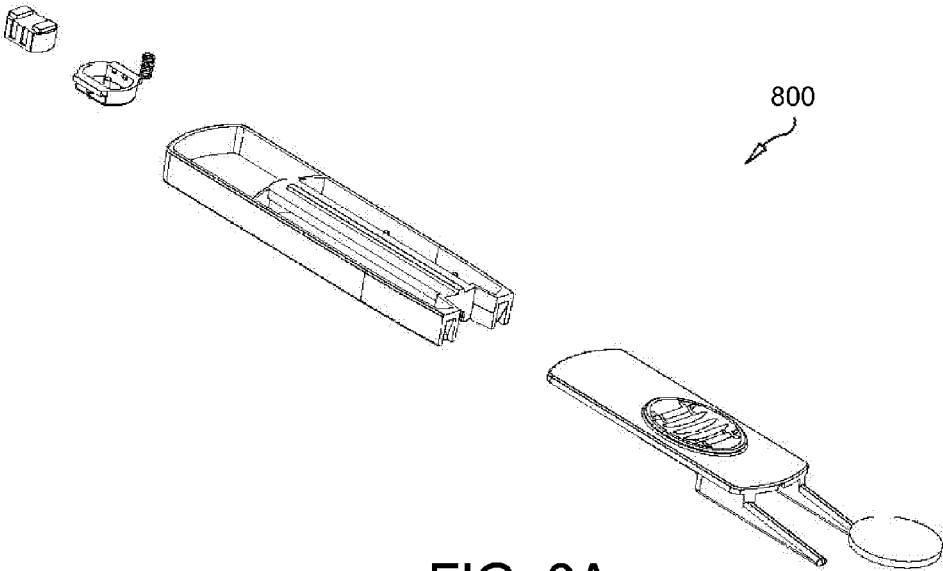

FIG. 8A

GOLF TEE MEASURING APPARATUS AND DIVOT REPAIR TOOL

BACKGROUND OF THE INVENTION

Field of the Invention

This invention relates to the game of golf and in particular, to a device measuring the length of a golf tee and replacing divots.

Description of the Related Art

A golfer's grip, stance, pivot, and follow-through all affect a golfer's work to achieve a consistent and ideal golf swing. The vertical point at which the face of the driver strikes the ball is also important. At the ideal striking point, a clubface makes initial contact with the midpoint of a golf ball at the driver's "sweet spot," or a portion of the clubface designed to provide the straightest drive. Initial contact with the ball above or below its center or above or below the clubface's sweet spot can result in excess spin, and a less accurate drive.

Golf tees are used by golfers to elevate the golf ball above the ground and facilitate contact at the ideal striking point. Conventional tees are typically made of wood or plastic, have a stake portion with a pointed end for insertion into the turf, and have a cupped end for supporting a ball. The optimal depth for insertion to facilitate the ideal striking point at a club's "sweet spot" is known to be the depth that allows the bottom of the club head to rest on the turf while the top of the club head is even with the center of the ball. Typically, the ordinary golfer inserts the tee into the ground relying upon his/her eyesight and best judgment to insert the tee into the turf at approximately the optimal depth.

The prior art teaches tee shafts having, for example lines, notches or a stopping mechanism, such as a removable or non-removable horizontal member that makes contact with the ground when the shaft is inserted to the proper depth.

A second problem with conventional tees, and one not addressed by the prior art, is the actual method of insertion depth estimation. Thus, while markings on a shaft may allow a golfer to insert his tee at the same depth each time, this does not guarantee that the depth consistently used is the optimal one. The fact that different tees differ in their overall height, and are marked in differing fashions, adds further complication. There exist no devices for efficiently inserting a tee into the ground with a predetermined length of shaft above the ground surface.

Although golfers are careful about positing their tees in the ground, tees often vary in their length, size and strength. A drawback of golf tees in the prior art are that they are not designed to allow the golfer to place the golf tee in the ground at the same depth every time, and the golfer cannot maintain the same body position every time. The golfer has to adjust his or her hands up or down the golf shaft to compensate for the varying height of the golf tee. Golfers' inability to judge the length of a tee and consistently place the tee at the same height distracts from a golfer's ability to concentrate on those factors mentioned above that require focus and practice. Problems with depth placement lead to loss of range and accuracy.

Additionally, when the ball lands on the green, it leaves a divot mark on the green. The golfer is expected to fix the divot on the green and divot tool is typically used for this green repair. Typically, these divots repaired as a matter of etiquette by the golfers. Divot repair tools combined with other golf devices do not exist in efficient form in the prior

art. Golfers additionally lack a device for holding a marker for marking the position of balls on a course or ground surface.

There exists a need in the art for a device that accurately measures the height of golf tees above ground, that allows a golfer to replace divots, and holds a marker like a coin. Current methods and apparatus are not effective.

SUMMARY OF THE INVENTION

From the foregoing discussion, it should be apparent that a need exists for a golf tee measuring device. Beneficially, such an apparatus would overcome many of the difficulties and safety concerns expressed, by providing a pocket-sized golf tee measuring device that can be quickly and easily used.

The present invention has been developed in response to the problems and needs in the art that have not yet been fully solved by currently available apparatus and methods. Accordingly, the present invention has been developed to provide a golf tee measuring device and divot repair tool, the comprising: a housing defining an open interior recess, the housing having a top surface, a distal end and a proximal end, the housing defining an open aperture on the proximal end for receiving a golf tee, the housing defining an open positioning slot running longitudinally part way across the top surface; a lower component slidably affixed to the housing such that the lower component travels longitudinally across a predetermined distance with respect to the housing, the lower component comprising: an interior surface having a guide track recessed into the interior surface, the guide track running in a longitudinal direction, the interior surface comprising a first set of retention members protruding upwardly within the open recess from the bottom surface; and, a pair of extrudable prongs for engaging a divot; a plurality of measurement markings imprinted on the top surface of the housing in parallel with the positioning slot for measuring a length of a golf tee inserted into the housing; a button extending which travels within the positioning slot and abuts the end of a golf tee inserted in the positioning slot.

The apparatus may further comprise a spring housed within the open recess between the button and a distal end of the housing, the spring biasing the button toward the proximal end of the measuring device.

The apparatus may further comprise an oblong pad integrated with the lower component and protruding downwardly therefrom, the oblong pad comprising a plurality of ribs for engaging a golfer's finger. The button may travel back and forth within the guide track in a longitudinal direction over a predetermined distance. The button may further comprise ribs for engaging a finger of the user.

The button may further comprise markings for aligning the button with the linear markings on the housing. In some embodiments, the button further comprises markings for aligning the button with the linear markings on the housing.

The lower component may slide longitudinally with respect to the housing to extrude the prongs from the housing, the prongs for stabbing and repairing a divot. The hollow interior recess may house a marker for marking the position of a golf ball on a ground surface.

A second golf tee measuring device and divot replacer is disclosed, the device comprising: a housing defining an open interior recess, the housing having a top surface, a distal end and a proximal end, the housing defining an open aperture on the proximal end for receiving a golf tee and a marker, the housing defining an open positioning slot running longitudinally

3

dinally part way across the top surface; a lower component slidably affixed to the housing such that the lower component travels longitudinally with respect to the housing, the lower component comprising: an interior surface having a guide track recessed into the interior surface, the guide track running in a longitudinal direction; and, a pair of retractable prongs for repairing a divot, the prongs enveloped within the housing when the lower component is slid rearward, the prongs extruded when the lower component is slid forward; a button extending which travels within the positioning slot and abuts the end of a golf tee inserted in the positioning slot.

The marker may be insertable and removable when the apparatus is in an extruded configuration.

These features and advantages of the present invention will become more fully apparent from the following description and appended claims, or may be learned by the practice of the invention as set forth hereinafter

BRIEF DESCRIPTION OF THE DRAWINGS

In order that the advantages of the invention will be readily understood, a more particular description of the invention briefly described above will be rendered by reference to specific embodiments that are illustrated in the appended drawings. Understanding that these drawings depict only typical embodiments of the invention and are not therefore to be considered to be limiting of its scope, the invention will be described and explained with additional specificity and detail through the use of the accompanying drawings, in which:

FIG. 1A is an elevational frontal-side perspective view of a device for measuring the length of a golf tee **100** with its divot repair tool retracted in accordance with the present invention.

FIG. 1B is an elevational frontal-side perspective view of a device for measuring the length of a golf tee **120** with its divot repair tool partially extruded in accordance with the present invention.

FIG. 1C is an lower perspective view of a device for measuring the length of a golf tee **140** with its divot repair tool extruded in accordance with the present invention.

FIG. 1D is an elevational frontal-side perspective view of a device for measuring the length of a golf tee in accordance with the present invention.

FIG. 1E is an environmental elevational frontal-side perspective view of a device for measuring the length of a golf tee and a golf tee in accordance with the present invention;

FIG. 2A is an elevational rear-side perspective view of a lower component of a device for measuring the length of a golf tee in accordance with the present invention;

FIG. 2B is an elevational rear-side perspective view of a lower component of a device for measuring the length of a golf tee in accordance with the present invention;

FIG. 3 is an elevational frontal-side perspective view of the housing of a device for measuring the length of a golf tee in accordance with the present invention;

FIG. 4 is a lower-side perspective view of the housing of a device for measuring the length of a golf tee in accordance with the present invention;

FIG. 5A is an elevational-side perspective view of the button of a device for measuring the length of a golf tee in accordance with the present invention;

FIG. 5B is an elevational-side perspective view of the button of a device for measuring the length of a golf tee in accordance with the present invention;

4

FIG. 6 is an elevational-side perspective view of the spring of a device for measuring the length of a golf tee in accordance with the present invention;

FIG. 7A is an elevational perspective view of a device for measuring the length of a golf tee in accordance with the present invention;

FIG. 7B is a forward (proximal) perspective view of a device for measuring the length of a golf tee in accordance with the present invention;

FIG. 7C is a distal (rearward) perspective view of a device for measuring the length of a golf tee in accordance with the present invention;

FIG. 7D is a side perspective view of a device for measuring the length of a golf tee in accordance with the present invention;

FIG. 7E is a lower perspective view of a device for measuring the length of a golf tee in accordance with the present invention; and

FIG. 8A is a lower perspective view of a disassembled device for measuring the length of a golf tee in accordance with the present invention.

DETAILED DESCRIPTION OF THE INVENTION

Reference throughout this specification to “one embodiment,” “an embodiment,” or similar language means that a particular feature, structure, or characteristic described in connection with the embodiment is included in at least one embodiment of the present invention. Thus, appearances of the phrases “in one embodiment,” “in an embodiment,” and similar language throughout this specification may, but do not necessarily, all refer to the same embodiment.

Furthermore, the described features, structures, or characteristics of the invention may be combined in any suitable manner in one or more embodiments. In the following description, numerous specific details are provided to provide a thorough understanding of embodiments of the invention. One skilled in the relevant art will recognize, however, that the invention may be practiced without one or more of the specific details, or with other methods, components, materials, and so forth. In other instances, well-known structures, materials, or operations are not shown or described in detail to avoid obscuring aspects of the invention.

Each of FIGS. 1A-1C show a golf tee measurer **100-140** in a different configuration. In FIG. 1A, the golf tee measurer **100** has its divot repair tool in a retracted position. The aspects of the device **100** are further described below. In FIG. 1B, the golf tee measurer **120** has its divot repair tool in a partially extruded position. In FIG. 1C, the golf tee measurer **140** has its divot repair tool in a fully extruded position. The device **140** houses a ball marker for marking the position of a golf ball on a putting or ground surface (which may be a quarter). The aspects of the device **140** are further described below.

FIG. 1D is an elevational frontal-side perspective view of a device **160** for measuring the length of a golf tee in accordance with the present invention. The measuring device **100** comprises a housing **102** defining an open aperture **104**, and a button assembly (i.e. button) **106**.

The housing **102** comprises a metal alloy or polymeric shell which defines an open interior recess. The front (or proximal end) of the housing **102** defines an open aperture **104** between two protruding extensions through which the shaft of a golf tee passes through. The golf tee, when inserted into the device **160**, protrudes through open aperture **104**,

5

with its cup abutting and engaging the slidable button **106** as further shown below. A golfer (or user or operator) of the measuring device is able to thus measure the length of the portion of the golf tee inserted into the device **160**, which is the same length of the golf tee rising above a ground surface when the protruding portion of the golf tee is pushed into a ground surface. A golfer may read graduated or linear markings engraved, imprinted, labeled, or printed on the top surface of the housing **102**, which correspond to the length of the golf tee above ground.

The length of the golf tee received by the housing **102** is adjustable by sliding the button **106** longitudinally within a track or positioning slot defined by the housing **102**.

FIG. 1E is an environmental elevational frontal-side perspective view of a device **180** for measuring the length of a golf tee in accordance with the present invention. The housing **102** of the measuring device **180** defines a positioning slot **254** (or open channel or track) (further defined below) running partially across the longitudinal axis (i.e. lengthwise axis) of the housing **102**.

The golf tee **152** which is inserted into the positioning slot **254** and protrudes through the open aperture **104**, is viewable by a user through the positioning slot **254**, where the golf tee **152** abuts the button **106**. The pointed, or tapered, end of the golf tee **152** shaft protrudes from the housing **102**, while the conical end of the golf tee **152** having the cups for holding the ball remains outside, or partially outside, the housing **102** within the positioning slot **254**.

FIG. 2A is an environmental elevational rear-side perspective view of lower component **200** of a device for measuring the length of a golf tee in accordance with the present invention.

The lower component **200** may be manufactured using methods known to those of skill in the art, including 3D printing. In the shown embodiments, the lower component **200** is fabricated from metal, elastomeric materials, or metal alloy for the purpose of adding strength to the prongs **210** used for replacing divots.

The lower component slides longitudinally within the housing **102**. When the lower component **200** is slid toward the front, or proximal end, of the housing **102**, the prongs **210** protrude from the housing **102**. In this manner the prongs **210** may be extruded for allowing a golfer to repair divots on the golf course. The prongs **210** are used for stabbing in fork-like fashion a divot which has been displaced by the ball landing on the putting surface.

The lower component **200** defines a guide track **204** within which a lower portion of the button **106** travels, which guide track **204** is recessed into the interior bottom surface **202** of the lower component **200**. The guide track **204** helps provide lateral stability to the button **106** as it travels on the longitudinal axis.

Two retention members **206a-b** rise upwardly within the interior recess of the housing **102** from the interior bottom surface **202** of the lower component. These retention members **206a-b** protrude from, are affixed to, and in some embodiments formed as a single integrated piece with, the interior bottom surface **202**.

Each of the retention members **206a-b** defines a hollow button recess **208** for receiving the button **106** in some embodiments. In depressing the button **106**, the user may drop the button **106** away from grooves along side the positioning slot which prevent longitudinal movement of the button **106** in some embodiments, thus freeing the button **106** to travel along the track **204**.

6

FIG. 2B is an environmental elevational rear-side perspective view of a lower interior surface of the component **200** for measuring the length of a golf tee in accordance with the present invention.

The retention members **206a-b** form, or define, a mid-channel **252** in which the button **106** may be partially housed or enveloped.

The sidewalls **210a-b** define an end channel **256** which is wider than the mid-channel for fixing/repairing divots and receiving a shaft of a golf tee **152**.

When the lower component **200** is slid forward, a hollow recess in the housing **102** may be exposed housing a quarter, coin, or other marker for marking the position of a golf ball on a ground surface.

When the prongs **210** are extruded, the device **100** is in an extruded configuration. When the prongs **210** are retracted, the device **100** is in a retracted configuration.

FIG. 3 is an elevational frontal-side perspective view of the housing **102** of a device **300** for measuring the length of a golf tee and repairing divots in accordance with the present invention.

The distal end **302** and proximal end **304** of the housing **102** are shown, as are the x- (longitudinal), y- (lateral), and z-axes.

FIG. 4 is a lower-side perspective view of the housing **400** of a device for measuring the length of a golf tee in accordance with the present invention.

In some embodiments, the lower component **200** comprises, or is affixed to, an oblong pad **402** for engaging the tip of a finger of the user. The oblong pad **402** juts downwardly from the exterior surface of the lower component **200**.

In various embodiments, the oblong pad **402** comprises an elliptically-shaped edge which circumscribes the oblong pad **402**. In other embodiments, the elliptical edge is recessed into the oblong pad **402** or the lower component **200**.

The oblong pad **402** may comprise protruding ridges or ribs **404a-e**, for engaging the finger of a user. The oblong pad **402** may also be described as an elliptical pad **402**.

When the lower component **200** is pushed forward by a golfer using the oblong pad **402**, the prongs **210** extrude from the housing for use in fixing divots.

The housing **102** defines a channel **406** or recess for receiving the shaft portion of the golf tee **152**.

FIG. 5A is an elevational-side perspective view of the button **500** of a device **160** for measuring the length of a golf tee in accordance with the present invention. The button **500** comprises ribs **502a-c** and a dome **502**.

The various embodiments the button **500** comprises the button **106**. In various embodiments, the button **500** comprises a dome **502** or convex dome rising upwardly from the top of the housing **102** and resting in the positioning slot **254** for engaging the finger of a user.

The button **500** may comprise markings **506** for aligning the button with graduated linear markings on the housing **102**. The button **500** may also comprise ridging or ribs **502a-c** for engaging a finger of a user. The button **500** may also comprise lateral engaging members **508** for engaging and snapping into c-shaped recesses along side the positioning slot **254**.

FIG. 5B is an elevational-side perspective view of the button **550** of a device for measuring the length of a golf tee **152** in accordance with the present invention. The golf tee measuring device **550** comprises a lower slot extension member **552**, a dome **502**, and a lateral engaging member **508**.

7

The lower slot extension member **552** juts downward from the bulk of the button assembly **550**. The lower slot extension member **552** runs within the slot **204**. The lateral engaging member **508** and dome **502** are substantially described above.

FIG. **6** is an elevational-side perspective view of the spring of a device **600** for measuring the length of a golf tee in accordance with the present invention.

The spring **602** is well known to those of skill in the art. In various embodiments, the spring **602** is disposed beneath, or rearwardly of, the button **106**. In other embodiments, the spring **602** and/or a second spring is disposed beneath the button **106** and the lower bottom surface **202** biasing the button **106** upwards on the z-axis.

FIG. **7A** is an elevational perspective view of a device **700** for measuring the length of a golf tee in accordance with the present invention.

As shown, in various embodiments, the positioning slot may be grooved or smooth.

FIG. **7B** is a forward (proximal) perspective view of a device **720** for measuring the length of a golf tee in accordance with the present invention.

As shown.

FIG. **7C** is a distal (rearward) perspective view of a device **740** for measuring the length of a golf tee in accordance with the present invention.

As shown.

FIG. **7D** is a side perspective view of a device **760** for measuring the length of a golf tee in accordance with the present invention.

As shown.

FIG. **7E** is a lower perspective view of a device **780** for measuring the length of a golf tee in accordance with the present invention.

As shown.

FIG. **8A** is a lower perspective view of a disassembled device for measuring the length of a golf tee in accordance with the present invention.

As shown.

The present invention may be embodied in other specific forms without departing from its spirit or essential characteristics. The described embodiments are to be considered in all respects only as illustrative and not restrictive. The scope of the invention is, therefore, indicated by the appended claims rather than by the foregoing description. All changes which come within the meaning and range of equivalency of the claims are to be embraced within their scope.

What is claimed is:

1. A golf tee measuring device and divot repair tool, the device comprising:

a housing defining an open interior recess, the housing having a top surface, a distal end and a proximal end, the housing defining an open aperture on the proximal end for receiving a golf tee, the housing defining an open positioning slot running longitudinally part way across the top surface;

a lower component slidably affixed to the housing such that the lower component travels longitudinally across a predetermined distance with respect to the housing, the lower component comprising:

an interior surface having a guide track recessed into the interior surface, the guide track running in a longitudinal direction, the interior surface compris-

8

ing a first set of retention members protruding upwardly within the open recess from the bottom surface; and,

a pair of extrudable prongs for repairing a divot mounted on the lower component;

a plurality of measurement markings imprinted on the top surface of the housing in parallel with the positioning slot for measuring a length of a golf tee inserted into the housing;

a button which travels within the positioning slot and abuts the end of a golf tee inserted in the positioning slot.

2. The apparatus of claim **1**, further comprising a spring housed within the open recess between the button and a distal end of the housing, the spring biasing the button toward the proximal end of the measuring device.

3. The apparatus of claim **1**, further comprising an oblong pad integrated with the lower component and protruding downwardly therefrom, the oblong pad comprising a plurality of ribs for engaging a golfer's finger.

4. The apparatus of claim **1**, wherein the button travels back and forth within the guide track in a longitudinal direction over a predetermined distance, locking in place when the button is released.

5. The apparatus of claim **1**, wherein the button further comprises ribs for engaging a finger of the user.

6. The apparatus of claim **1**, wherein the button further comprises markings for aligning the button with the linear markings on the housing.

7. The apparatus of claim **1**, wherein the button further comprises markings for aligning the button with the linear markings on the housing.

8. The apparatus of claim **1**, wherein the lower component slides longitudinally with respect to the housing to extrude the prongs from the housing, the prongs for stabbing and repairing a divot.

9. The apparatus of claim **1**, wherein the hollow interior recess houses a marker for marking the position of a golf ball on a ground surface.

10. A golf tee measuring device and divot repair tool, the device comprising:

a housing defining an open interior recess, the housing having a top surface, a distal end and a proximal end, the housing defining an open aperture on the proximal end for receiving a golf tee and a marker, the housing defining an open positioning slot running longitudinally part way across the top surface;

a lower component slidably affixed to the housing such that the lower component travels longitudinally with respect to the housing, the lower component comprising:

an interior surface having a guide track recessed into the interior surface, the guide track running in a longitudinal direction; and,

a pair of retractable prongs for repairing a divot, the prongs enveloped within the housing when the lower component is slid rearward, the prongs extruded when the lower component is slid forward;

a button which travels within the positioning slot and abuts the end of a golf tee inserted in the positioning slot.

11. The apparatus of claim **1**, wherein the marker is insertable and removable when the apparatus is in an extruded configuration.

* * * * *